

- NOTES:**
1. VERTICAL DATUM = NAVD88
 2. AERIAL PHOTO, TOPOGRAPHY (1 FT. CONTOUR INTERVAL) AND FIELD SURVEY INFORMATION PROVIDED BY PSOMAS.
 3. SECTION 404 WATERS OF THE U.S. JURISDICTIONAL LIMITS PROVIDED BY THE TOWN OF MARANA.
 4. FEMA FLOODPLAIN INFORMATION PER FEMA FIRM PANELS: 04019C1045L, 04019C1065L, 04019C1070L AND 04019C1080L.

LEGEND

	FEMA FLOODPLAIN LIMITS
	WATERSHED BOUNDARY
	ESTIMATED PONDING/100-YR FLOODPLAIN LIMITS
	CROSS-SECTION ID WITH 100-YR WATER SURFACE ELEVATION
	RIGHT OF WAY LINE
	EXISTING EASEMENT LINES
	PROPERTY BOUNDARY
	404 JURISDICTIONAL WATERS
	FEMA FIRM 100-YR BASE FLOOD ELEVATIONS

PRELIMINARY

CMG DRAINAGE ENGINEERING, INC.
 3555 N. Mountain Ave. Tucson, Arizona 85719
 Phone (520) 882-4244 Fax (520) 888-1421

**FIGURE 5
 EXISTING DRAINAGE
 CONDITIONS**

TANGERINE ROAD
 1-10 TO LA CANADA DR.

SHEET 3 OF 6

PROJECT NO:	10-027
DESIGN:	JKW
CHECKED:	JLC
DRAWN:	CRB
DATE:	02/28/2012
REV DATE:	12/20/2012
REV DATE:	
REV DATE:	

Z:\PROJECTS\10101027 Psoamas-Tangerine Rd 1-10 to La Canada\Drawings_Base.dwg, Fig 5 Ext Cond 1.3, 12/27/2012 10:26:27 AM

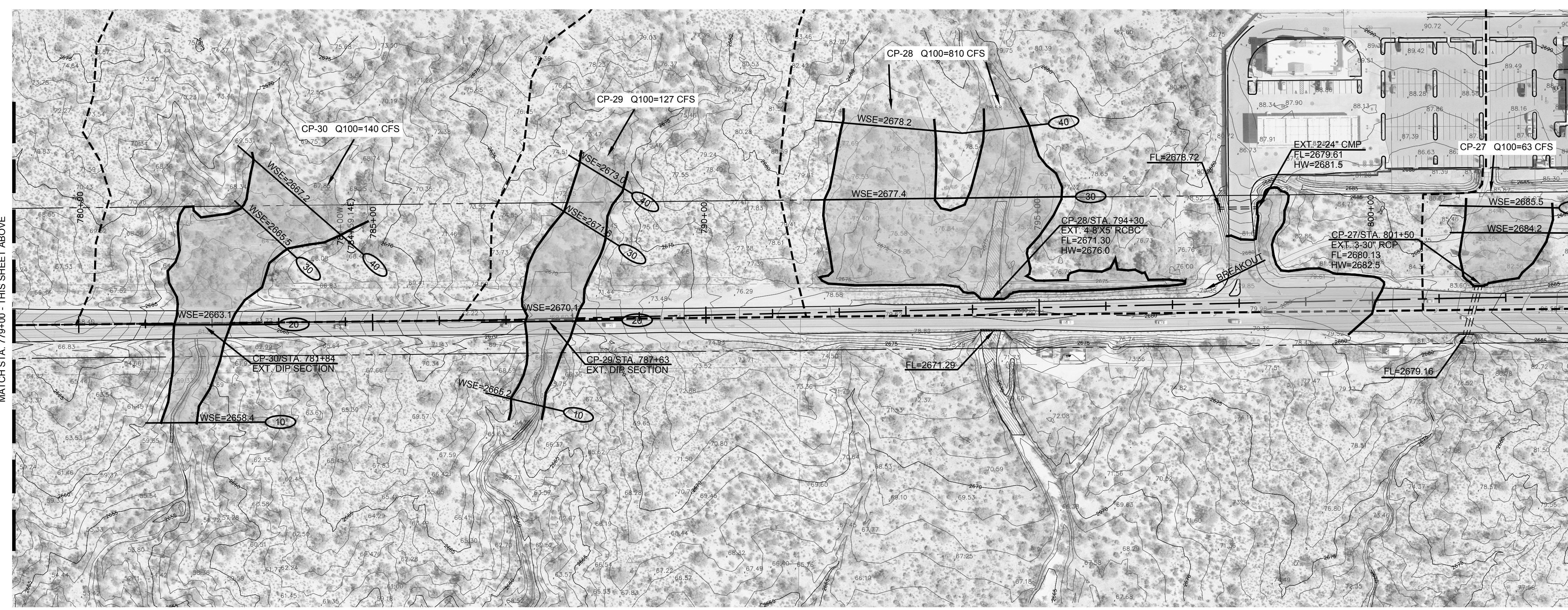
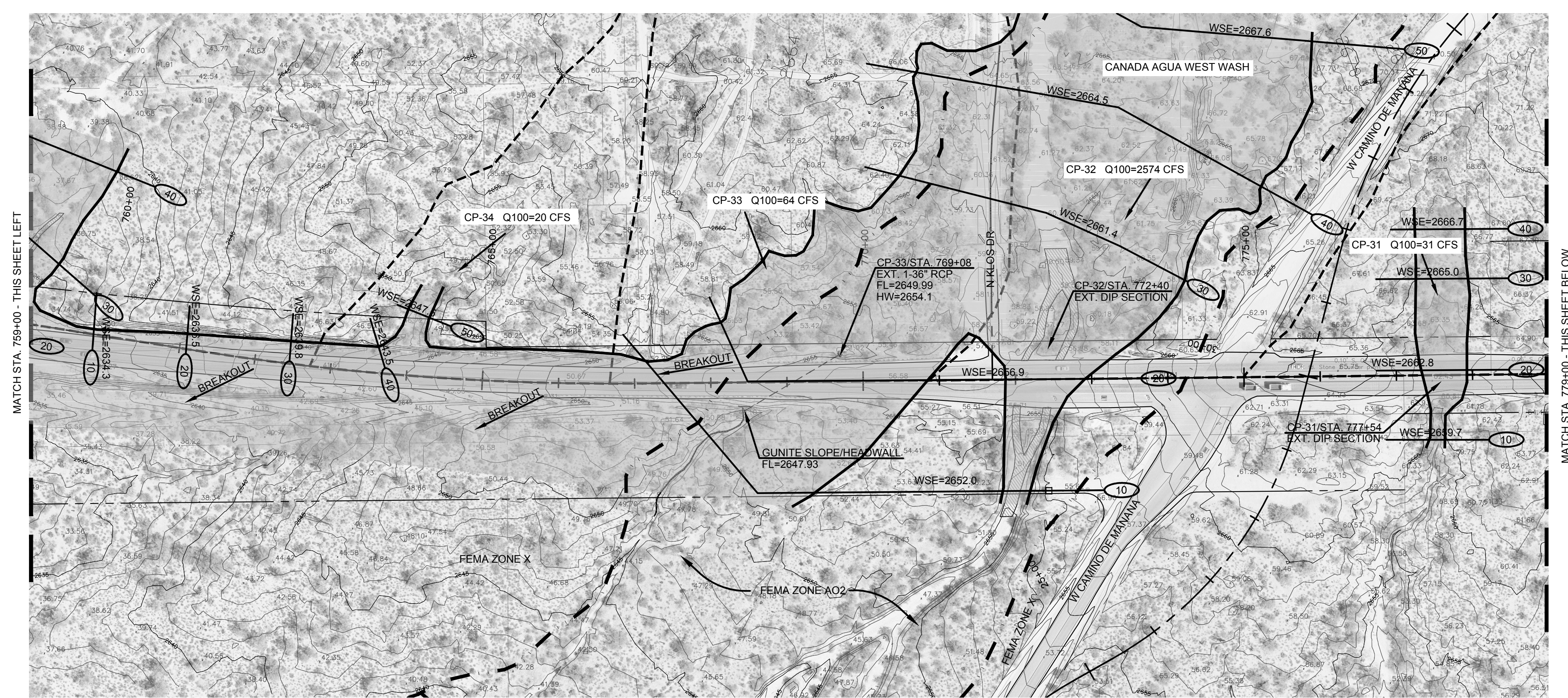
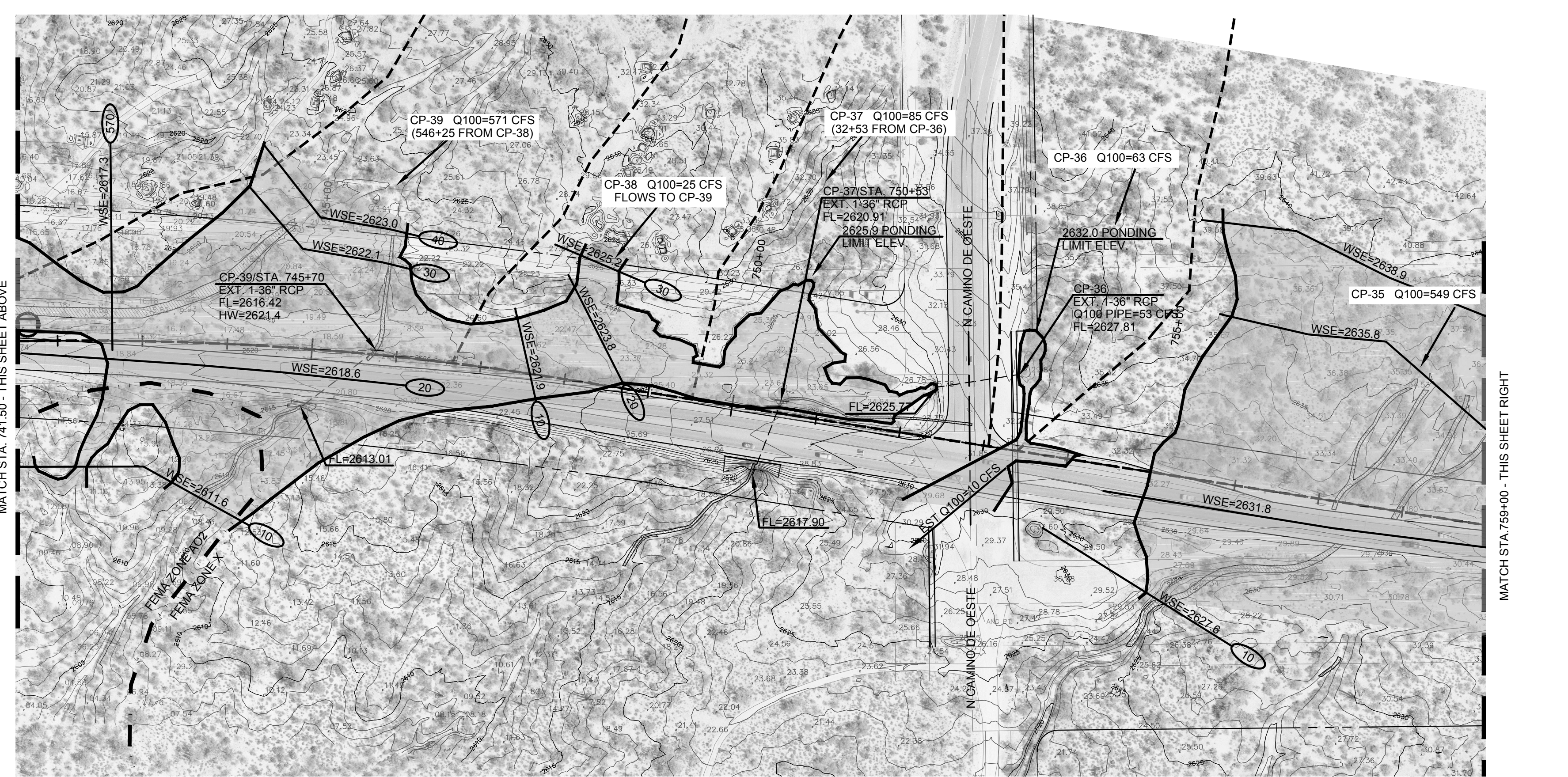
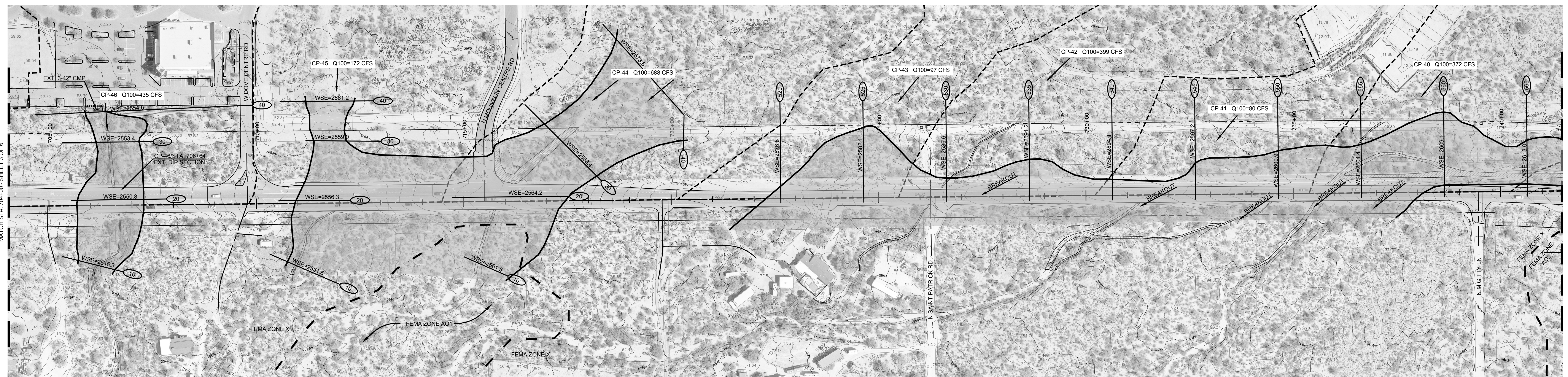

SHEET 1	SHEET 2	SHEET 3	SHEET 4	SHEET 5	SHEET 6
---------	---------	---------	---------	---------	---------

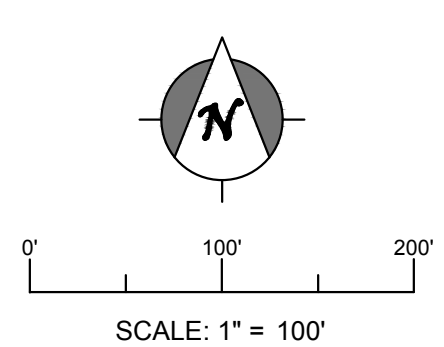

- NOTES:**
1. VERTICAL DATUM = NAVD88
 2. AERIAL PHOTO, TOPOGRAPHY (1 FT. CONTOUR INTERVAL) AND FIELD SURVEY INFORMATION PROVIDED BY PSOMAS.
 3. SECTION 404 WATERS OF THE U.S. JURISDICTIONAL LIMITS PROVIDED BY THE TOWN OF MARANA.
 4. FEMA FLOODPLAIN INFORMATION PER FEMA FIRM PANELS: 04019C1045L, 04019C1065L, 04019C1070L AND 04019C1080L.

LEGEND

	FEMA FLOODPLAIN LIMITS
	WATERSHED BOUNDARY
	ESTIMATED PONDING/100-YR FLOODPLAIN LIMITS
	CROSS-SECTION ID WITH 100-YR WATER SURFACE ELEVATION
	RIGHT OF WAY LINE
	EXISTING EASEMENT LINES
	PROPERTY BOUNDARY
	404 JURISDICTIONAL WATERS
	FEMA FIRM 100-YR BASE FLOOD ELEVATIONS

PRELIMINARY

CMG DRAINAGE ENGINEERING, INC.
 3555 N. Mountain Ave. Tucson, Arizona 85719
 Phone (520) 882-4244 Fax (520) 888-1421

**FIGURE 5
 EXISTING DRAINAGE
 CONDITIONS**

TANGERINE ROAD
 1-10 TO LA CANADA DR.

SHEET 4 OF 6

PROJECT NO:	10-027
DESIGN:	JKW
CHECKED:	JLC
DRAWN:	CRB
DATE:	02/28/2012
REV. DATE:	12/20/2012
REV. DATE:	
REV. DATE:	

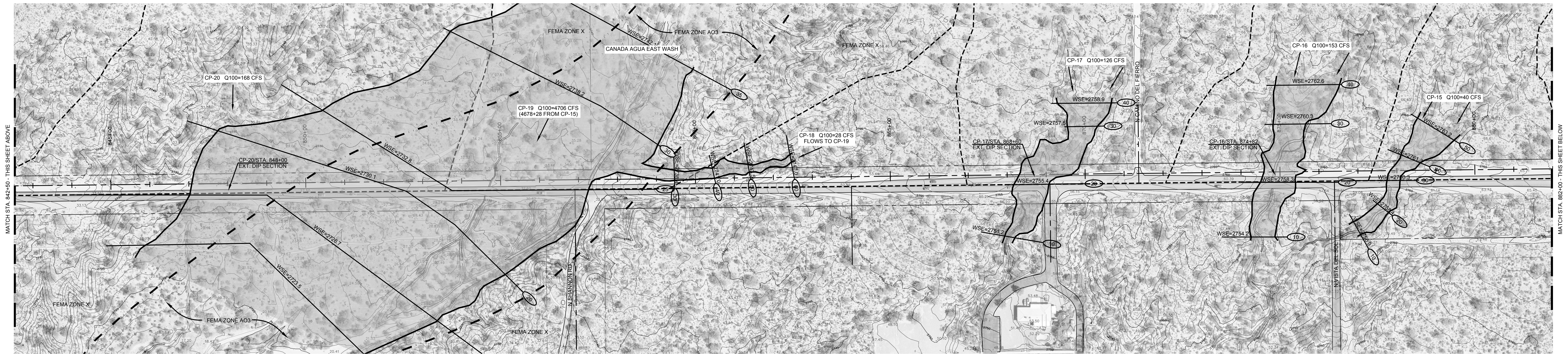
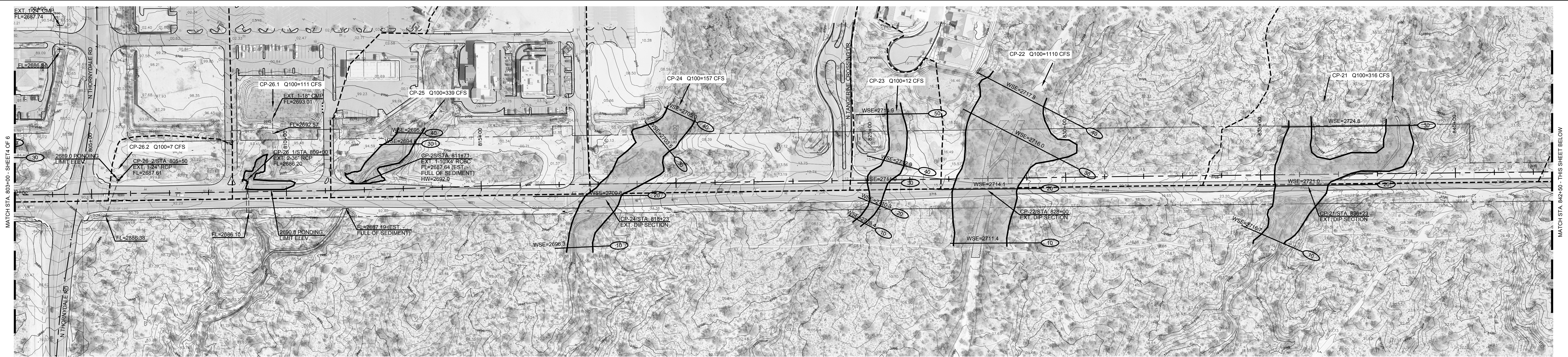

SHEET 1 SHEET 2 SHEET 3 SHEET 4 **SHEET 5** SHEET 6

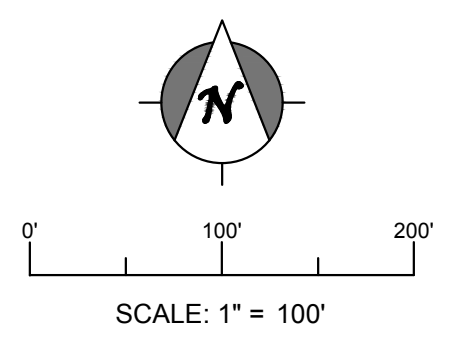

- NOTES:**
1. VERTICAL DATUM = NAVD88
 2. AERIAL PHOTO, TOPOGRAPHY (1 FT CONTOUR INTERVAL) AND FIELD SURVEY INFORMATION PROVIDED BY PSOMAS.
 3. SECTION 404 WATERS OF THE U.S. JURISDICTIONAL LIMITS PROVIDED BY THE TOWN OF MARANA.
 4. FEMA FLOODPLAIN INFORMATION PER FEMA FIRM PANELS: 04019C1045L, 04019C1065L, 04019C1070L AND 04019C1080L.

LEGEND	
	FEMA FLOODPLAIN LIMITS
	WATERSHED BOUNDARY
	ESTIMATED PONDING/100-YR FLOODPLAIN LIMITS
	CROSS-SECTION ID WITH 100-YR WATER SURFACE ELEVATION
	RIGHT OF WAY LINE
	EXISTING EASEMENT LINES
	PROPERTY BOUNDARY
	404 JURISDICTIONAL WATERS
	FEMA FIRM 100-YR BASE FLOOD ELEVATIONS

PRELIMINARY

CMG DRAINAGE ENGINEERING, INC.
 3555 N. Mountain Ave. Tucson, Arizona 85719
 Phone (520) 882-4244 Fax (520) 888-1421

PROJECT NO:	10-027
DESIGN:	JKW
CHECKED:	JLC
DRAWN:	CRB
DATE:	02/28/2012
REV. DATE:	12/20/2012
REV. DATE:	
REV. DATE:	

FIGURE 5
EXISTING DRAINAGE
CONDITIONS
 TANGERINE ROAD
 1-10 TO LA CANADA DR.
 SHEET 5 OF 6

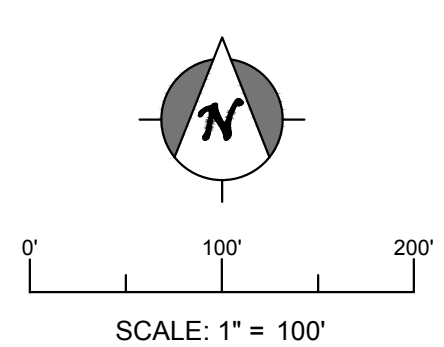
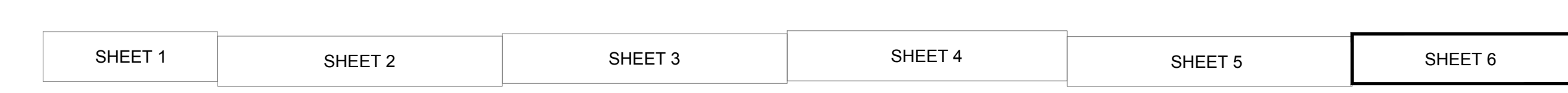
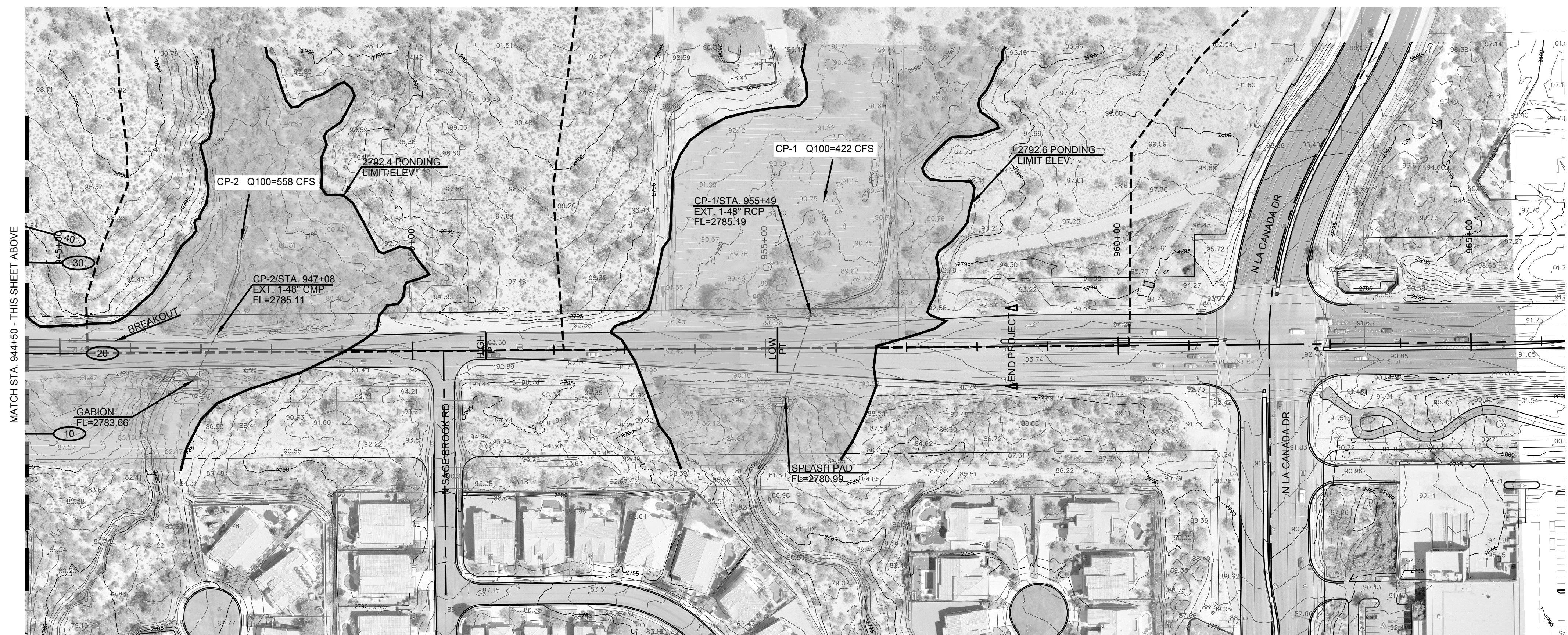
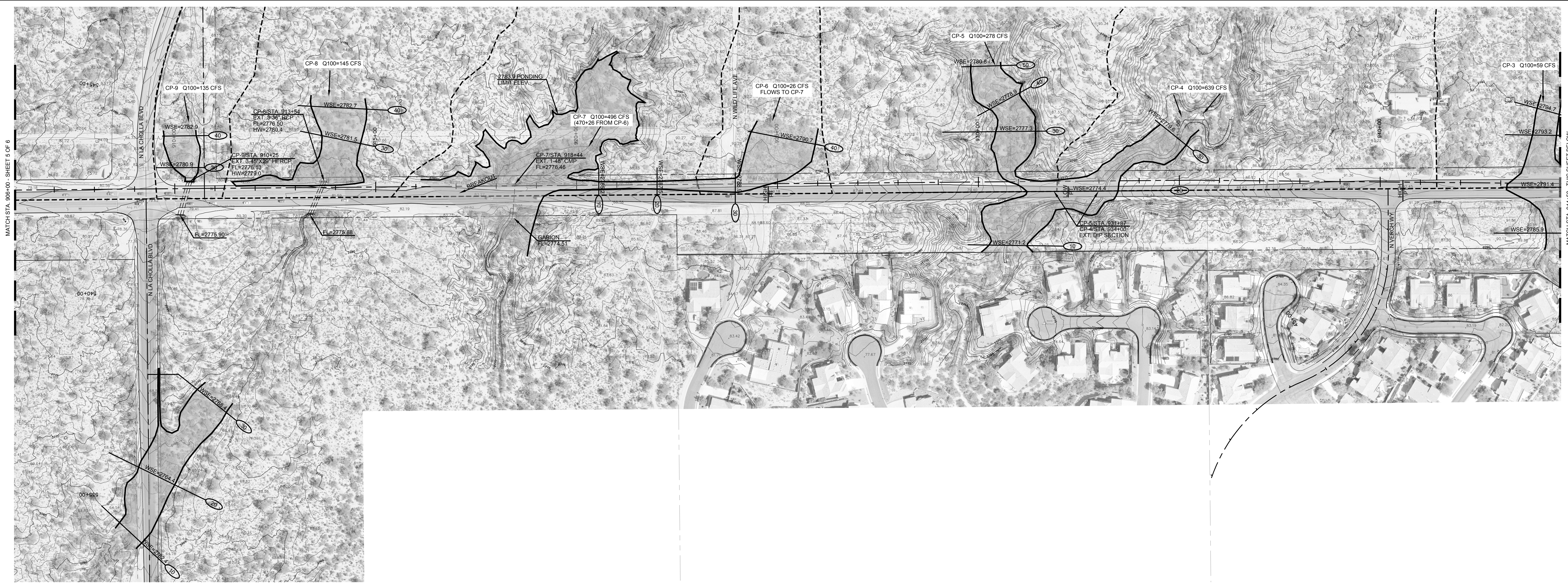

- NOTES:**
1. VERTICAL DATUM = NAVD88
 2. AERIAL PHOTO, TOPOGRAPHY (1 FT CONTOUR INTERVAL) AND FIELD SURVEY INFORMATION PROVIDED BY PSOMAS.
 3. SECTION 404 WATERS OF THE U.S. JURISDICTIONAL LIMITS PROVIDED BY THE TOWN OF MARANA.
 4. FEMA FLOODPLAIN INFORMATION PER FEMA FIRM PANELS: 04019C1045L, 04019C1065L, 04019C1070L AND 04019C1080L.

LEGEND	
	FEMA FLOODPLAIN LIMITS
	WATERSHED BOUNDARY
	ESTIMATED PONDING/100-YR FLOODPLAIN LIMITS
	CROSS-SECTION ID WITH 100-YR WATER SURFACE ELEVATION
	RIGHT OF WAY LINE
	EXISTING EASEMENT LINES
	PROPERTY BOUNDARY
	404 JURISDICTIONAL WATERS
	FEMA FIRM 100-YR BASE FLOOD ELEVATIONS

PRELIMINARY	<p>CMG DRAINAGE ENGINEERING, INC. 3555 N. Mountain Ave. Tucson, Arizona 85719 Phone (520) 882-4244 Fax (520) 888-1421</p>
<p>PROJECT NO: 10-027 DESIGN: JKW CHECKED: JLC DRAWN: CRB DATE: 02/28/2012 REV DATE: 12/20/2012 REV DATE:</p>	

Z:\PROJECTS\2010\10-027 Psoamas-Tangerine Rd 1-10 to La Canada\Drawings_Base.dwg, Fig 5 Ext Cond 4-6, 12/27/2012 10:33:14 AM